

MATERIAL:

FINISH:

DURBAR PLATE SIGHTING BAR 30x30x3mm PSA

MATERIAL SPEC. :- BS.EN 10025 : S275 JR
WELDED TO STAIRTREADS AS FOLLOWS :-

1. TO END PLATES 3mm FULL PROFILE WELD OUTSIDE ONLY.
2. TO 1st SPAN BAR 3mm WELD INSIDE ONLY AS SHOWN BELOW.

Length of Tread	No.of welds	Length of weld
Up to 1000mm Lg	3	40mm Min.
1001-1625mm Lg	4	40mm Min.

WELDS TO BE EQUALLY SPACED ALONG THE LENGTH. THE ABOVE WELDING SEQUENCE APPLIES TO BOTH MANUAL WELDING AND WELDING BY ROBOT.

SPAN BARS

EACH SPAN BAR TO BE FULLY WELDED TO END PLATES ONE SIDE ONLY.

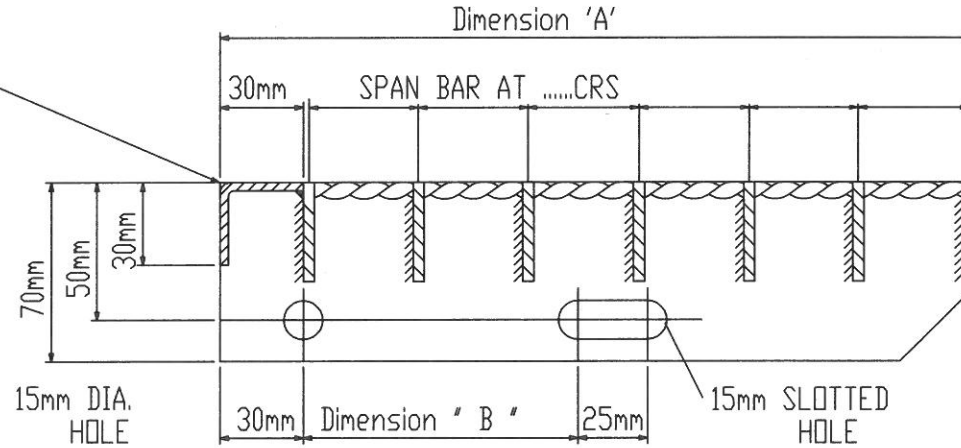

NOTE :- WHEN Dim.B IS 75mm, TREADS ARE SUPPLIED WITH ROUND HOLES ONLY.

TYPE	TREAD REF	BAR THK.	Dim.A	Dim.B	Dim.A	Dim.B	Dim.A	Dim.B	Dim.A	Dim.B	Dim.A	Dim.B
41/100 ; 41/50	FD509	3mm	158mm	75mm	199mm	100mm	240mm	100mm	281mm	100mm	322mm	100mm
30/100 ; 30/50	FD509	3mm	155mm	75mm	185mm	75mm	215mm	100mm	245mm	100mm	275mm	100mm
33/100 ; 33/50	FD509	3mm	167mm	75mm	200mm	100mm	233mm	100mm	266mm	100mm	299mm	100mm
41/100 ; 41/50	FD509	5mm	160mm	75mm	201mm	100mm	242mm	100mm	283mm	100mm	324mm	100mm
30/100 ; 30/50	FD509	5mm	157mm	75mm	187mm	75mm	217mm	100mm	247mm	100mm	277mm	100mm



LIONWELD KENNEDY

Marsh Road, Middlesbrough, Cleveland TS1 5JS
Telephone 01642 245151 Fax 01642 224710 Telex 587279 LWAK G

DO NOT SCALE

IF IN DOUBT ASK

REF. DRGS.

SUBJECT DURBAR TREAD DETAILS

FIXING CLIPS
SADDLE/STANDARD

No OFF	TYPE	No OFF	TYPE

SCALE 1:20

No. OF
PANELS

DRAWN BY RSC

DATE 16/08/10

CLIENT:

ISSUE	DATE	ISSUE	DATE	ISSUE	DATE
02		01		00	

DATE

ISSUE

DATE

ISSUE

ISSUED FOR

DATE

05.09.09

CHECKED BY AC

APPROVED L.Mc.

DRG. No

LKFL-STD-94 00

ISSUE